

## DURABILITY OF COMPACTED ENERGY CROP BIOMASS

Edgars Repsa, Eriks Kronbergs, Emils Pudans

Latvia University of Agriculture

edgars.repsa@llu.lv, eriks.kronbergs@llu.lv, emils.pudans@llu.lv

**Abstract.** The purpose of the work is to investigate mechanical durability of briquettes and pellets of energy crop biomass. Briquettes were produced from common reed (*Phragmites Australis* L.), reed canary grass (*Phalaris arundinacea* L.) and mixture of peat with common reeds and reed canary grass but pellets from reed canary grass and peat mixture. Briquettes and pellets mechanical durability test was realized according to the LVS EN 15210 standard. The durability is the measure of the resistance of compacted fuels to affection of shocks and abrasion as a consequence of handling and transportation processes. It is stated as percentage of remaining mass of biofuel after sieving. The requirement of standards (LVS EN 14961-1:2010) for mechanical durability of low quality briquettes is <90.0 % (minimum value to be stated) and high quality briquettes  $\geq 95.0$  %, but mechanical durability of low quality pellets is <95.0 % (minimum value to be stated) and high quality pellets  $\geq 97.7$  %. The results of the mechanical durability test show that mechanical durability of energy crop pellets changes from 82.4 to 97.6% and mechanical durability of energy crop briquettes changes from 87.5 to 95.5 %. Mechanical durability of pellets and briquettes depends on the peat proportion in mixture.

**Keywords:** compacted energy crops, mechanical durability.

### Introduction

Firewood, agricultural straw, and herbaceous energy crops are the most prominent biomass energy sources. In Latvia, approximately 14.6 % [1] of unfarmed agricultural land can be used for herbaceous energy crop growing. Herbaceous energy crops would be the main basis for solid biofuel production in agricultural ecosystem in future. Reed canary grass is grown in recent years and is recommended for solid biofuel production. Beside that there is a possibility to utilize for bioenergy production natural biomass of common reeds overgrowing the shorelines of Latvian more than 2000 lakes.

Peat can be used as the best additive for manufacturing of solid biofuel, because it improves the density, durability of stalk material briquettes (pellets) and avoids corrosion of boilers.

The mechanical durability test can indicate the maximum stress that the compacted products can withstand. Durability and density are the main parameters describing the physical quality of compacted solid biofuels – pellets and briquettes. Both fuel types are exposed to mechanical wear during handling, transportation, and storage. Therefore, durability is an important quality parameter that is stated in standards. Particle density is another parameter, which is commonly taken as a measure of durability, e.g., high particle density leads to high mechanical durability.

The strength and durability of the briquettes and pellets depend on the physical forces that bond the particles together. The binding forces have been categorized into several groups: solid bridges, attraction forces between solid particles, mechanical interlocking bonds, adhesion and cohesion forces, interfacial forces and capillary pressure [2]. The effectiveness of the inter-particle bonds created in the compacting process has been evaluated in terms of strength and durability of the produced briquettes and pellets. The mechanical durability test can help control the compacting process and briquettes and pellets quality in the solid fuel manufacturing industry. High durability means high quality of briquettes and pellets.

The goal of the work is to investigate the mechanical durability of briquettes and pellets of energy crop biomass. The briquettes were produced from common reed, reed canary grass and mixture of peat with common reeds and reed canary grass but the pellets from reed canary grass and peat mixture.

### Materials and methods

Testing briquettes was produced by the hydraulic press. The cross section of the die was 60x150 mm. Maximal pressure of the press hydraulic system – 225 bar. For stalk herbaceous biomass comminuting a hammer mill was used. The machine was equipped with 15 kW electric motor and three different screens with round shaped opening size 6, 12 and 20 mm. The peat proportion in the mixture was 15 and 30 %. The briquette density was determined from the ratio of the mass to the

volume of the briquette. The weight of the briquette was measured on electronic scales with division 0.1 g and the size of the briquettes was measured with sliding calipers (division 0.1 mm).

The pellets were produced by a flat die pellet mill, equipped with 4 kW electrical motor. The flat die hole size was 6 mm. The pellets were produced from reed canary grass and mixture of reed canary grass and peat. For reed canary grass biomass comminuting a hammer mill was used with two different screen opening sizes 3 and 6 mm. The peat proportion in the mixture was 20, 30 and 50 %. The pellet bulk density was determined according to the LVS EN 15103 standard [3].

The moisture content was determined according to the standard LVS EN 14774-2:2010, where oven drying of the samples was carried out at  $105\pm 2$  °C [4].

The briquette and pellet mechanical durability test was realized according to the LVS EN 15210:2011 standard. The standard LVS EN 15210-1:2011 defines the requirements and the method used for testing the mechanical durability of pellets but the standard LVS EN 15210-2:2011 is used for briquettes. The test sample is subjected to controlled shocks by collision of briquettes or pellets against each other and against the wall of a specified rotating test chamber. During the durability test of briquettes the test portion (minimum 2 kg) was placed in the durability drum. The samples were rotated at drum velocity  $21\pm 0.1$  min<sup>-1</sup> for 5 minutes. Afterwards, the samples were passed through a sieve, with dimensions 45x45 mm. The remaining part of the samples on the sieve was weighed for briquette durability calculation. The scheme and dimensions of the testing equipment of the briquette durability test drum are shown in Fig. 1.

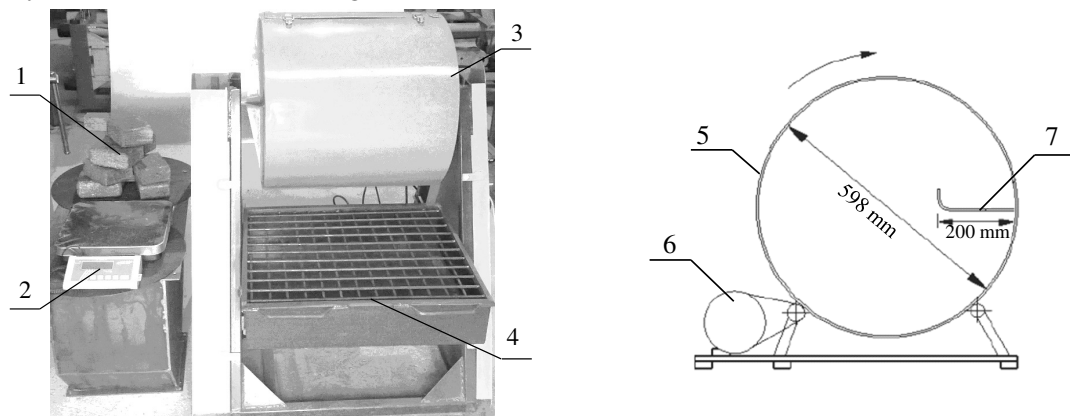

Fig. 1. Durability drum scheme and dimensions: 1 – briquettes; 2 – scales; 3 – durability drum; 4 – sieve; 5 – drum; 6 – motor; 7 – baffle

The durability test of reed canary grass and peat mixture pellets was performed in the Forest and Wood Products Research and Development Institute. The scheme and dimensions of the testing equipment of the pellet durability tester are shown in Fig. 2.

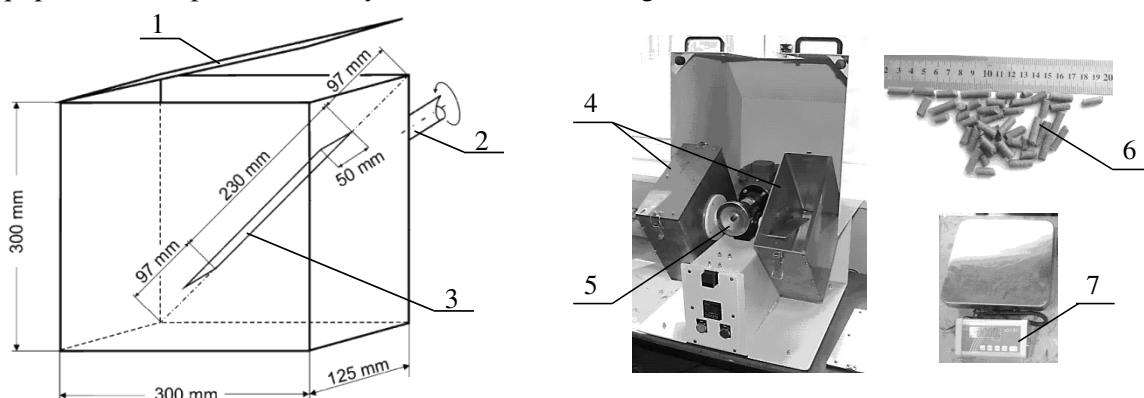

Fig. 2. Structure and main parts of the pellet tester: 1 – filling door; 2 – drive shaft; 3 – baffle; 4 – containers; 5 – motor; 6 – reed canary grass pellets; 7 – scales

The mechanical durability of briquettes and pellets was calculated as mass proportion remaining on the sieve to the total sample weight using the following equation:

$$DU = \frac{m_A}{m_E} 100, \quad (1)$$

where  $DU$  – mechanical durability in percent, %;  
 $m_E$  – mass of pre-sieved briquettes/pellets before the drum treatment, g;  
 $m_A$  – mass of sieved briquettes/pellets after the drum treatment, g.

The weight of the briquette and pellet mass was measured on electronic scales with division 0.1 g. The mean values of mechanical durability were calculated from five replications. MS Excel software was used for statistical evaluation of the results.

## Results and discussion

Mechanical durability of common reed, reed canary grass and mixture of peat with common reeds and reed canary grass briquettes was calculated by equation (1). The results are shown in Fig. 3 and Fig. 4.

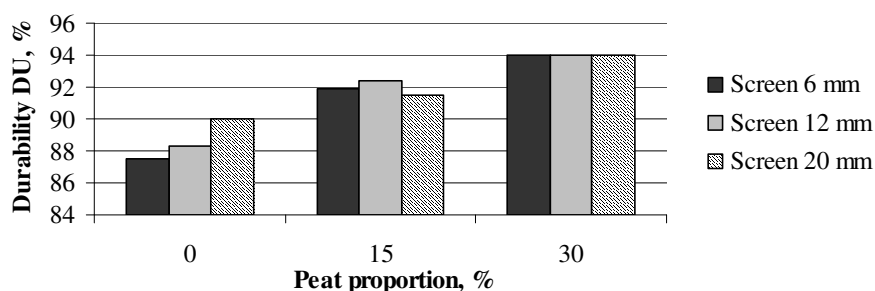

Fig. 3. Durability of common reed and peat mixture briquettes

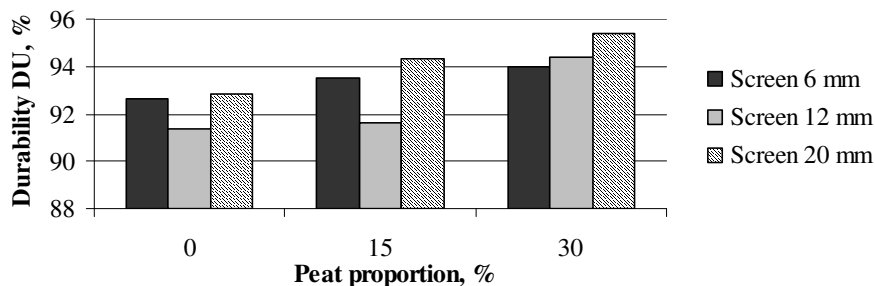

Fig. 4. Durability of reed canary grass and peat mixture briquettes

The results of the mechanical durability test of common reed and peat mixture briquettes show that durability increases if increasing the peat proportion in mixture up to 30 %. Minimal average value was determined  $87.5 \pm 4.1$  % for common reed briquettes (biomass comminuting screen 6 mm), but maximal average durability  $94.1 \pm 1.8$  for common reed and peat mixture briquettes (biomass comminuting screen 6 mm and peat proportion in mixture 30 %). Common reed and peat mixture briquettes average density values change from  $775.9 \pm 22.1$  to  $870.1 \pm 9.7$   $\text{kg} \cdot \text{m}^{-3}$ . Briquette density depends on the particle size and peat proportion in mixture. Biomass material moisture range was from 11.0 to 14.5 %.

The results of the mechanical durability test of reed canary grass and peat mixture briquettes also show that durability increases if increasing the peat proportion in mixture up to 30 %. Minimal average value was determined  $91.4 \pm 1.8$  % for reed canary grass briquettes (biomass comminuting screen 12 mm), but maximal average durability  $95.5 \pm 1.6$  for reed canary grass and peat mixture briquettes (biomass comminuting screen 20 mm and peat proportion in mixture 30 %). Reed canary grass and peat mixture briquettes average density values change from  $806.3 \pm 14.7$  to  $889.1 \pm 11.8$   $\text{kg} \cdot \text{m}^{-3}$ . Briquette density depends on the particle size and peat proportion in mixture. Biomass material moisture range was from 12.7 to 15.8 %.

The obtained results show that the produced briquettes can be classified in different quality classes depending on the measured durability and density values. The produced briquettes from stalk

energy crop biomass and peat can be extended to medium and low quality solid biofuel. The produced briquettes are suitable for use in household.

The mechanical durability test results of reed canary grass and mixture of peat with reed canary grass pellets are shown in Fig. 5.

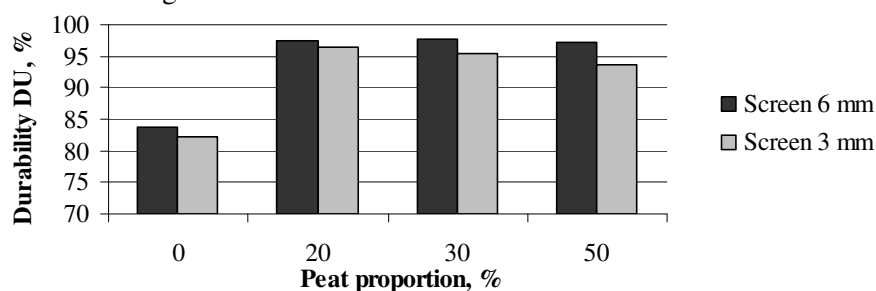

Fig. 5. Durability of reed canary grass and peat mixture pellets

Minimal average value was determined  $82.4 \pm 1.2\%$  for reed canary grass pellets (biomass comminuting screen 3 mm), but maximal average durability  $97.6 \pm 1.6$  for reed canary grass and peat mixture briquettes (biomass comminuting screen 6 mm and peat proportion in mixture 30%). The produced pellets with different durability can be classified for low and high quality solid biofuel. Peat can be used for pellet quality improvement.

Reed canary grass and peat mixture pellet average bulk density values vary in a range between  $458.4 \pm 11.7$  and  $636.6 \pm 18.8 \text{ kg} \cdot \text{m}^{-3}$ . A guiding value for the bulk density of biomass pellets is specified in the standard LVS EN 14961-1:2010. Biomass pellet bulk density values in the standard of low quality pellets is  $\geq 550 \text{ kg} \cdot \text{m}^{-3}$  and high quality pellets  $> 700 \text{ kg} \cdot \text{m}^{-3}$  (maximal value to be stated). The bulk density measurement results show that satisfactory average bulk density can be obtained using reed canary grass and peat mixture where minimal peat proportion is more than 20%. Biomass material moisture range is from 13.8 to 16.4%.

## Conclusions

The results indicate that mechanical durability of pellets and briquettes depends on the peat proportion in mixture. Minimal average value was determined  $87.5 \pm 4.1\%$  for common reed briquettes but maximal average durability  $94.1 \pm 1.8$  for common reed and peat mixture briquettes. Common reed and peat mixture briquettes average density values change from  $775.9 \pm 22.1$  to  $870.1 \pm 9.7 \text{ kg} \cdot \text{m}^{-3}$ . Minimal average value for briquettes was determined  $91.4 \pm 1.8\%$  for reed canary grass, but maximal average durability  $95.5 \pm 1.6$  for reed canary grass and peat mixture. Reed canary grass and peat mixture briquette average density values change from  $806.3 \pm 14.7$  to  $889.1 \pm 11.8 \text{ kg} \cdot \text{m}^{-3}$ . Minimal average value was determined  $82.4 \pm 1.2\%$  for reed canary grass pellets, but maximal durability  $97.6 \pm 1.6$  for reed canary grass and peat mixture briquettes. Reed canary grass and peat mixture pellet average bulk density values vary in a range between  $458.4 \pm 11.7$  and  $636.6 \pm 18.8 \text{ kg} \cdot \text{m}^{-3}$ .

## References

1. Land politics statement for years 2008. – 2014. The Order of the Cabinet of Ministers of the Republic of Latvia Nr. 613 (in Latvian), <http://www.mk.gov.lv>, (Accessed on 17.03.2014).
2. Kaliyan N., Vance Morey R. (2008) *Densification of biomass: mechanisms, models, and experiments on briquetting and pelleting of biomass*. VDM Verlag: Saarbrücken, Germany, 336 p. ISBN: 978-3-639-05185-8.
3. LVS EN 15103:2010 standard "Solid biofuels – Determination of bulk density".
4. LVS EN 14774-2:2010 standard "Solid biofuels – Determination of moisture content – Oven dry method – Part 2: Total moisture – Simplified method".