

IMPROVING ENERGY PERFORMANCE OF EQUIPMENT FOR PRODUCTION OF PEELED VENEER

Jury Kalugin, Alexander Alifanov
Baranovichi State University
yustk@list.ru

Abstract. The rapid growth of data volumes and rates of production and economic processes entails modernization of the existing equipment in order to save raw materials and energy resources. The article deals with issues of concern to improve the equipment for peeling veneer, displaying possible upgrading of mechanical parts of machine tools and methods to control the equipment based on the optimal interaction of the elements that make up the equipment for peeling veneer. Options for upgrading the mechanical parts, equipment management methods based on optimal interaction of the elements of machines for peeling veneer are considered. The article lists the advantages of the developed methods, block diagrams and drawings of fragments of the devices.

Key words: vibrations thickness of veneer, dynamic properties, energy loss, optimal control, complex manufacturing equipment, saving energy resources.

Introduction

In today's enterprises the value of rational organization of the production process of manufacturing plywood, improved efficiency of equipment and coordination of technical controls and monitoring has increased. To extend the necessary management information, speed and accuracy are needed. The volume and speed of production and economic processes are also significant. All of these became important factors in determining the level of labour and production organization and the final results of a plywood company. The processes of plywood production have changed significantly and require considerable energy, labour and material costs. Therefore, for effective management of plywood now specialized equipment is needed, the work of what is based on the optimization of the use of computer technology.

A special place in the complex structure of the technological process of production of plywood is production of raw veneer. In order to save energy and improve the efficiency, the equipment operates on site sorting and filing logs for veneer peeling machines and direct peeling, requires substantial upgrading. Two directions are typically used: improvement of the mechanical system of machines, development of methods to control the equipment on the basis of optimal interaction.

Materials and methods

As it is known, the thickness of the peeled veneer is the deviation from the calculated average, as well as periodic oscillations along the length of the tape. The causes of fluctuations thickness of peeled veneer are as follows: kinematic error circuitry slide; limited and unstable stiffness nodes shelling machine; uneven wood density determined by the anisotropy of its properties, the heating temperature fluctuations, fluctuations in the values of sensitive factors of the shelling, the degree of crimp, rear angle, orientation parameters of a knife and a ruler, etc.

The field size dispersion veneer thickness, as a result of the influence of error of the individual kinematic chain, slide presentation, according to prof. Kulikov, for the exploited types of rays shelling machine averages $a = 0.1-0.15$ mm. Among the causes of fluctuations in the thickness of rotary-cut veneer, the largest share is the dynamic errors caused by the limited violence of individual units shelling machine [3]. The design of the telescopic spindle unit contains a large number of related Mezhujev elements (Figure 1). Under the influence of load on the spindle the parameters that characterize the relationship between the elements are changed, it alters the dynamic properties of the object and the additional loss of energy.

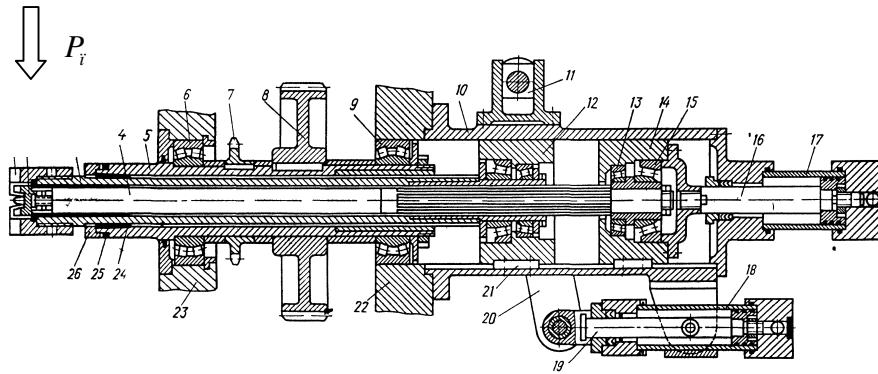

Fig. 1. **The design model spindle unit:** 1 – outer spindle cam; 2 – cam internal spindle; 3 – outer spindle; 4 – inner spindle; 5 – shaft; 6, 9, 13, 15 – bearings; 7 – star; 8 – gear; 10 – sleeve; 11 – bearing; 12, 14 – clips; 16, 19 – stocks; 17, 18 – cylinder; 20 – leather; 21 – dowel; 22, 23 – rack frame; 24 – sleeve; 25 – lining; 26 – nut

Changes in dimensional chains, which characterize the deformation of the spindle, can be seen from the diagram of elastic deformation (Figure 2).

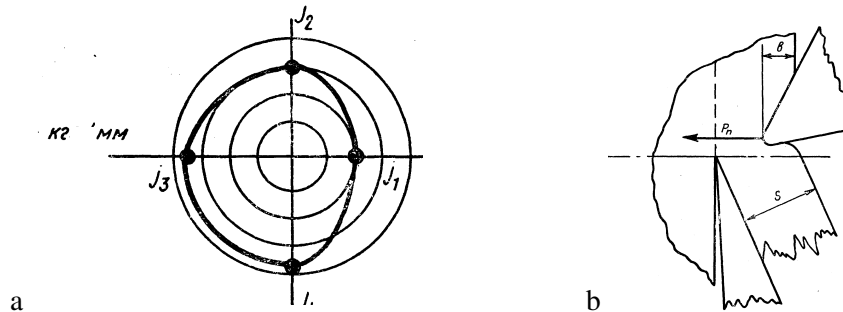

Fig. 2. **Influence of the efforts of elastic deformations:**
 a – diagram of elastic deformation, b – diagram of the impact of efforts at cutting wood

At any time, peeling the elastic displacement spindles are:

$$y_1 = \frac{P_r}{j_1}, \tag{1}$$

where P_r – the horizontal component of cutting force-feeding;

j_1 – the rigidity of spindles at this point.

Due to the fact that in the next point increment in the elastic strain is:

$$\Delta y = y_1 - y_2 = P_r \left(\frac{1}{j_1} - \frac{1}{j_2} \right). \tag{2}$$

Presenting j_2 in the form of $j_1 + \Delta j$, we obtain:

$$\Delta y = \Delta S = \frac{P_r \Delta j}{j_1 (j_1 + \Delta j)}. \tag{3}$$

To obtain absolutely rigid timber, despite the change in the efforts $y_1 = y_2$ and $\Delta S = 0$.

Making of the caliper to the desired stiffness can be done by different classical means [3]: on the basis of hydraulic prop caliper, using “floating line” and other well-known foreign Shelling machines using “floating line” on the basis of hydraulic prop to ensure continuity crimping veneer is much less effective than the possible use of “floating calliper”. Low rigidity of such a line, strictly corresponding to the cutting forces can not have any noticeable impact on reducing the thickness of the veneer fluctuations. The greatest efficiency can be obtained by reducing the number of links dimensional chain and changing the design elements with the module parameter optimization.

Development of methods for optimal control equipment. One important aspect in addressing the cost of wood raw materials and reduce energy costs, along with the introduction of new technologies may be the development of methods to control the equipment for peeling veneer-based computer systems. The use of modern devices to digitize the surfaces of round timber and parametric systems modelling will significantly increase the accuracy of the orientation of logs in peeling, develop and coordinate a device providing an increase in volumetric yield of veneer and plywood cost of raw materials, electrical and thermal energy.

Results and discussion

Research in this area for several years has been held in the Belarusian State Technological University (Minsk). As a result of the research an alternative technology of peeling on the exact home assortments [1, 2] has been developed and it is composed of terms of reference for the development of pilot-based device coordinate type with electronic control. The layout scheme of the developed complex equipment is given in Figure 3. The equipment, in accordance with the layout scheme works as follows: assortments come in the shop on a conveyor belt 1 and then coordinate-measuring device 2 measures and fixes the coordinates of the surface. After measuring the coordinates of the surface the assortment of on-screen operator tracks the sequence of operations and volumetric characteristics of alleged shelling areas. After a preliminary measurement and digitization, downgraded assortments are served on a conveyor belt in a separate department for processing.

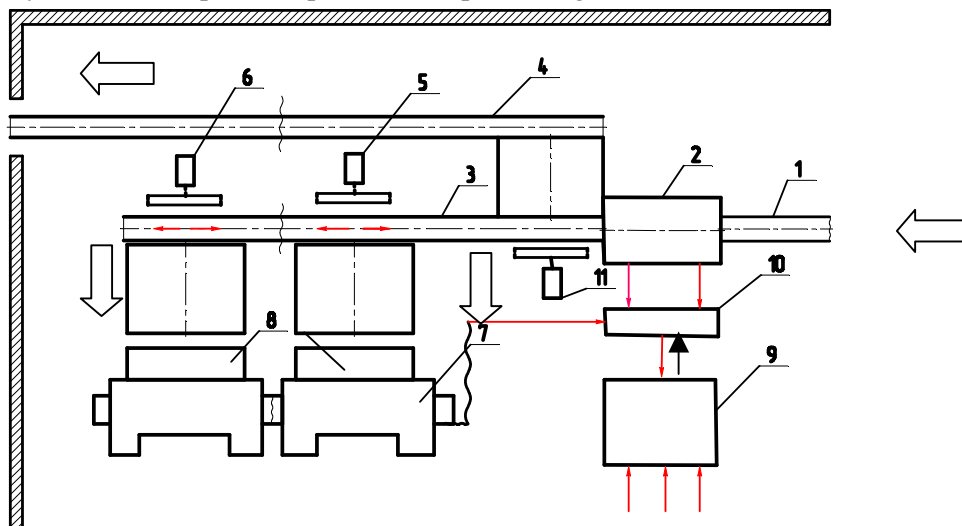

Fig. 3. **Layout of equipment in the area peeled veneer:** 1, 3, 4 – longitudinal conveyor; 2 – jig-scanning device; 5, 6, 11 – faces of the device; 7 – peeling machine; 8 – based devices (X-Y); 9 – computer system; 10 – interface unit

After measuring the coordinates of the surface assortment of on-screen monitor operator tracked the sequence of operations. After a preliminary measurement and digitization, downgraded assortments are served on a conveyor belt in a separate department for processing. If you have special equipment and technology assortments arriving for processing, they can serve as a strong source used as additional products of plywood company. Assortment parameters, which correspond to the normative values on the conveyor belt 3 into the based device 8, which is fitted in the coordinate system, were oriented in accordance with the control program. Capture and consolidation of logs in the working spindles is produced with the aid of manipulators comprising the peeling machine 7. Monitoring and adjustment of automated devices is done by using the command devices on the remote control of the computer system 9. To implement the developed technology the standard equipment used in shelling plants can be used. Additional sets: based device (8), computer system (9) and coordinate scanner (2).

In 2008, work to create a complex for the home and loading of logs was continued in Baranovichi University at the Department of Automation of Production, led by Professor Chair, Doctor of Technical Sciences – Alexander Alifanov. Currently, a draft is set of the equipment for plywood production. The complex will include scanners, coordinate movement of logs.

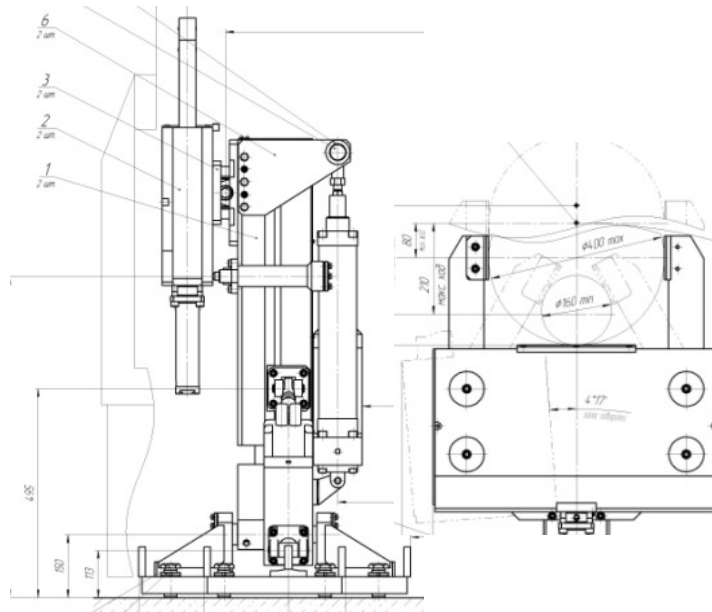

Fig. 4. Fragments of the drawings for the complex based logs

The main advantages of the developed complex:

- saving of plywood raw materials and energy resources
- increasing the volume yield of veneer at the expense of accurate home assortments
- the possibility of accounting information and assortments of each zone, shelling, followed by an entry in a centralized database;
- continuous monitoring of products and all types of losses of wood;
- improving the quality of veneer through the use of valuable outer of the assortment and reduced release of little veneer.

All the above benefits provide savings of raw materials and energy resources in the peeled veneer and create conditions for increasing the efficiency of veneer production.

Conclusions

These main directions of modernization of the main equipment used in plywood production, are not unique. Based on the above information, we can formulate the following conclusions.

1. The use of computer modelling and design for applications in production problems will accurately calculate the trajectory of the elements of machines and evaluate the feasibility of using certain types of raw materials (including raw materials with defects), a more rational use of energy sources.
2. Office equipment based CNC systems will automate the cycle of loading and unloading machines and increase the smoothness of the coordinate movements, XY – the movement of logs using CNC systems will allow to accurately determine coordinates of the axis of rotation and reduce waste.
3. These methods of improvement of peeling machines will result in savings of raw materials and energy resources.

References

1. Kalugin J. Comparative analysis of methods based plywood logs. Timber Industry, Moscow, 2004, No 5, pp. 16-17.
2. Kalugin J. Special way home plywood logs. Timber Industry of Belarus, Minsk, 2005, No 3, pp. 19-21.
3. New in the manufacture of plywood, chipboard and plastics. Proceedings of the Central research veneer institute. Moscow: TSNIIF, 1989, vol. 11, pp. 34-39.